

WORKSTATION FLUSH MOUNTING - 2X4 / 3X4 / 4X4 MODULES (REF. 83401 S / 83402 S / 83403 S)

DESCRIPTION



- Workstation to be installed in masonry or in hollow walls by using claws.
- To be used with semi-assembled devices **QUADRO 45** Series.
- Available in color **BR** - White.

INSTALLATION

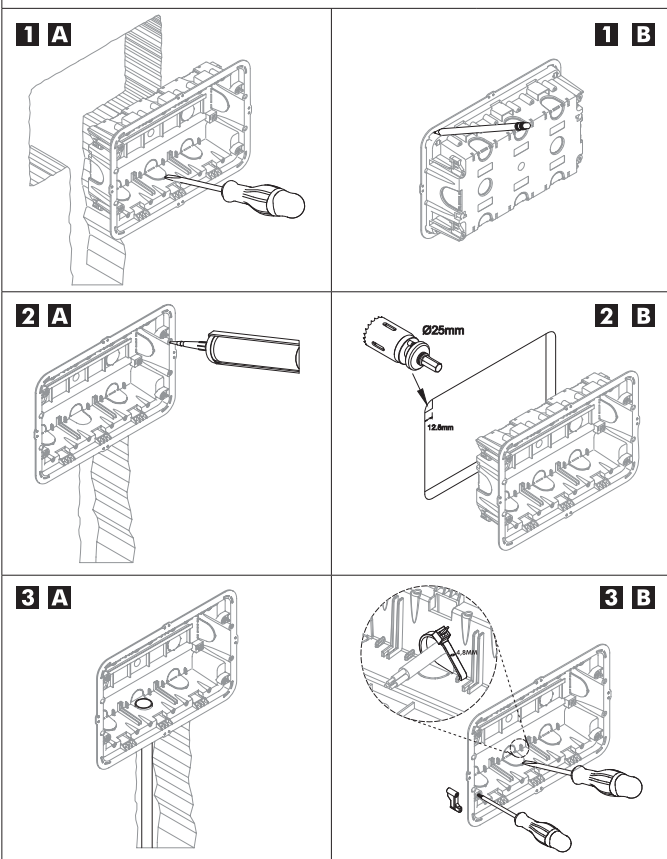

MOUNTING DIAGRAM

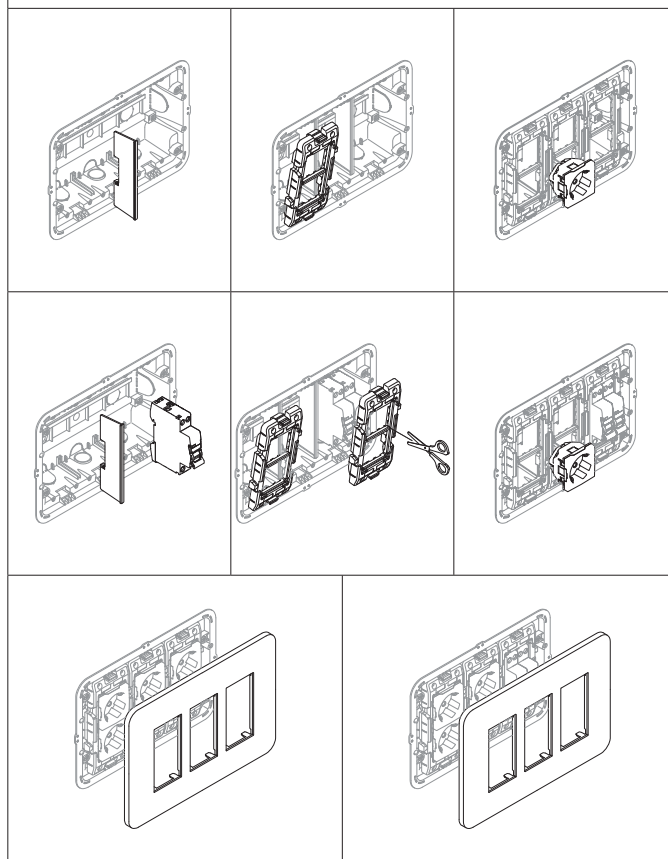

DIMENSIONS (mm)

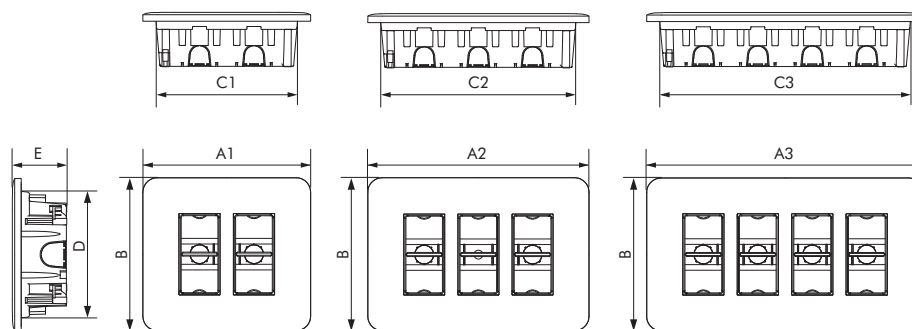

A1 (mm)	A2 (mm)	A3 (mm)	B (mm)	C1 (mm)	C2 (mm)	C3 (mm)	D (mm)	E (mm)
185	245	305	170	157	217	277	142	50

SECTION 7	CLASSIFICATION	WORKSTATION FLUSH MOUNTING
7.1	Nature of the material	Insulating
7.2	Type of installation	Embedded, semi-embedded or integrated: walls or ceilings, non-combustible; walls or ceilings, combustible; hollow or partitions (false ceilings, walls), furniture.
7.3	Types of inlets (outlets)	With inlets for plain or corrugated pipes
7.4	Means for fixing cables and pipes	With cables retention
7.5	Minimum and maximum temperatures during the installation	-5°C to +60°C
7.7	Boxes or enclosures for hollow or partitions, classified according to 7.2.1.3	Degree of protection of the enclosure: IP3XC
7.8	Means for fixing the devices to the boxes	Boxes designed to allow other means of fixing
7.102	Enclosure	PD Enclosure (for predetermined equipment)
	Resistance of the recessed housing part enclosure embedded area (back case box) to the glow wire test at 850°	
	IK Test - IK07	
	The maximum permissible load inside the enclosure 2x4 is 1.4 Kg (The maximum load was verified by the maximum weight of the MCB applied and with an increase of 1.5)	
	The maximum permissible load inside the enclosure 3x4 is 2.1 Kg (The maximum load was verified by the maximum weight of the MCB applied and with an increase of 1.5)	
	The maximum permissible load inside the enclosure 4x4 is 2.8 Kg (The maximum load was verified by the maximum weight of the MCB applied and with an increase of 1.5)	
	Rated Voltage - 250V~ Rated Current - 63A	
	Maximum Capacity to Dissipate Power (Pde) - 40W	

INFORMATION

ANNEX BB	CLASSIFICATION	WORKSTATION FLUSH MOUNTING
BB3	Devices to be Integrated by the Installer	The devices integrated in the enclosure by the installer shall comply with their applicable product standards, (e.g. 1 MCB shall comply with IEC 60898-1, 1 RCCB shall comply with IEC 61008-1 and 1 RCBO shall comply with IEC 61009-1). The sockets shall comply with IEC 60884-1 and have safety shutters (Ref. 45132 S, 45112 S). Compatible with devices 45x45 - QUADRO45.
BB5	Connections	Terminals must be used in accordance with the standards EN 60998-2-1.
BB6	Protection Against Electric Shock	Active parts shall remain not accessible after devices are installed in the enclosure. Devices mounted in the enclosure shall have a minimum IP degree of IP2X
BB8	Wiring	The installation must ensure that the internal wiring shall be such that minimum creepage distances between live parts and metallic accessible or non-accessible parts are not lower than 3mm. The cross-sections of conductors shall be in accordance with the wiring rules

EN 50085-1

SECTION 9	CLASSIFICATION	WORKSTATION FLUSH MOUNTING
9.4	Mechanical connections by screws	0,8Nm

IEC 60884-1 NP 1260

SECTION 9	CLASSIFICATION	WORKSTATION FLUSH MOUNTING
9.4	Fixing of low voltage devices	90N×1,5= 135N

